



MINIFOR wiretalje

Ubegrænset wirelængde da wiren kører igennem taljen. MINIFOR kan anvendes til mange formål indenfor forskellige industrier, lifte og elevatorer, bygninger, håndværk, metalarbejde, industri generelt.

Programmet består af MINIFOR TR 10 og TR 30 for generel brug, og TR 30S og TR 50 til brug ved store højder.

Fordele:

- Stor kapacitet/lav egenvægt.
- Ubegrænset wire længde.
- Hurtig og nem installation.
- Fjernbetjening (op/ned).
- Kabellængde 2,5 mtr.
- Aluminium alloy design.
- Forsynet med svirveltopkrog.
- Beskyttelse: IP 55 (styring: IP 65).
- Automatisk afbryderkontakt (op/ned).

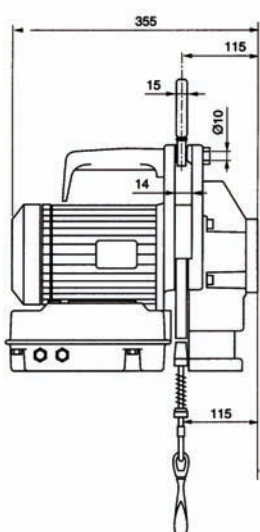

TR10 / TR30

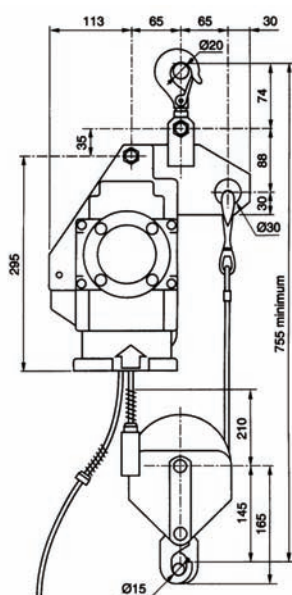

TR10 / TR30

MINIFOR

The principle of the wire rope passing completely through the machine allows unlimited height of lift. The MINIFOR has many applications in different industries, lifts and elevators, building, crafts, metalwork, general industry.

The range consists of the MINIFOR TR 10 and TR 30 for general use and TR 30S and TR 50 for use on high level building sites.

Advantages:

- Excellent capacity / weight ratio.
- Unlimited wire rope travel.
- Light and fast set up.
- Remote control (up/down).
- Cable length 2,5 mtr.
- Aluminium alloy design.
- Swivelling suspension hook.
- Protection: IP 55 (Control: IP 65).
- Upper and lower limit switches.



TR 10



TR 30



TR 50

Art. No.	Model	Cap. kg	Speed m/min.	Wire rope dia. mm	Weight kg
05-1067010	TR 10	100	15	6,5	20
05-1067030	TR 30	300	5	6,5	20.2
05-1067030S	TR 30S	300	13	6,5	31.6
05-1067050	TR 50	500	7	6,5	31

Valgmuligheder for motor: 230-400 V/ enkelt fase + 3-faset.

Specialt bloksæt kan leveres til alle modeller. De muliggør en fordobling af kapaciteten og halvering af hastigheden. ED% 40. Radiostyret med „løfte/sænke“ funktion.

Options for motor: 230-400 at single phase and 3-phased.

Special sleeve block kits are available for all models. They enable doubling the capacity half the working speed. Duty Factor 40%. Radio remote control with „lower“ function.



Wireopsoling 20-27-40 m.

Wire reeler 20-27-40 mtr.

Tirak

Elektrisk talje for løft og træk af materiel

- Ubegrænset løftehøjde; wiren lagres ikke i taljen
- Sammenlignet med dens kapacitet (op til 3000kg), er TIRAK meget nemt at håndtere og ekstremt kompakt og flyttes nemt fra sted til sted.
- Centrifugal bremse for kontrolleret fastholdelse i tilfælde af strømudfald.
- Fjernbetjening (op/ned). Kabellgd. 3 mtr. Wire længde 3 mtr.
- TIRAK T-1000 kan trække i 2 retninger med nominal last.
- Kan flytte byrder til-og-fra.



X3000



XA300



L500



Mobilewinch

Tirak

Electric hoist for material lifting and pulling

- Unlimited height of lift; the wire rope is not stored in the machine.
- Compared to its capacity (up to 3.000 kg), the TIRAK® is very easy to handle and extremely compact, and may be simply moved from site to site.
- Centrifugal brake for controlled descent in case of powerfailure.
- Pendant control with up/down and emergency stop.
- Cable length 3 mtr.
- The TIRAK T-1000 can pull in 2 directions with nominal load.
- They can move loads to-and-fro.

Model	WLL	Lifting speed m (min)	Motor type ³⁾	Specification ¹⁾			TIRAK® wirerope ø mm	Weight kg
				Powerconsumption kW	Dutyfactor %			
X 300	300	9	T	0,5	100		8	27
X 302	300	18	T	0,9	100		8	27
X 301	300	9	M	0,5	100		8	29
X 400	400	9	T	0,9	100		8	29
X 402	400	18	T	1,8	100		8	31
X 403	400	9/18	T	0,9/1,8	100		8	35
X 401	400	9	M	0,9	100		8	32
X 500	500	9	T	0,9	100		8	40
X 502	500	18	T	1,8	100		8	43
X 503	500	9/18	T	0,9/1,8	100		8	47
S 501	500	9	M	0,9	100		8	49
X 800	800	9	T	1,6	100		8	45
X 802	800	18	T	3,2	100		8	49
X 805	800	4,5/9	T	0,8/1,6	100		8	50
X 803	800	9/18	T	1,75/3,5	100		8	49
X 1020	980	9	T	1,9	100		9	45
X 1025	980	4,5/9	T	0,9/1,9	100		9	55
X 1026	980	4,5/18	T	0,9/3,8	100		9	71
X 1023	980	9/18	T	1,9/3,8	100		9	56
T 1020	980	9	T	1,9	100		9	71
T 1025	980	4,5/9	T	0,9/1,9	100		9	84
T 1026	980	4,5/18	T	0,9/3,8	100		9	94
T 1023	980	9/18	T	1,9/3,8	100		9	85
X 3050 ⁴⁾	3000	6	T	3,8	100		14	105
X 3052 ⁴⁾	3000	12	T	7,5	60		14	117

- Ekstra: trinløs hastighed, anden spænding og talje med hydraulisk eller pneumatisk motor.
- Ved brug af wireblok er det muligt at øge kapaciteten på taljen.
- T = 3-faset 400V - 50 Hz; M = 1-faset 230 V - 50 Hz; H = hydraulisk.
- Med lastbegrænser.
- Kan leveres for personløft.
- Kan leveres som mobilt spil med wireopruller.

- Options: adjustable speed, other voltages and hoist with hydraulic or pneumatic motor.
- By using a sheave block it is possible to increase the capacity of the hoist.
- T = 3-phase 400V - 50 Hz; M = 1-phase 230 V - 50 Hz; H = hydraulic.
- With load limiter.
- Available for manriding.
- Available as mobile winch with wire rope reeler.

Specifications and products are subject to change / Der tages forbehold for trykfejl og udgåede varer

TIRFOR wiretalje

Tirfor løfte- og træketalje er et universalværktøj, som arbejder i alle stillinger: horisontal, vertikal og vinklet.

- Ubegrænset wirelængde.
- Arbejder med millimeters nøjagtighed.
- Nem og sikker at betjene.
- Hurtig og nem installation.
- Nemt at fæde og fjerne wire.
- Meget let på grund af aluminiumshus.
- Nemt at rengøre og servicere.
- Brudstifter bryder ved 25% overlast.
- Trækstang bøjer ved 50% overlast.
- Øgning af løfte- og trækcapacitet ved brug af flerskivede blokke.
- Type TU er godkendt til personløft*.

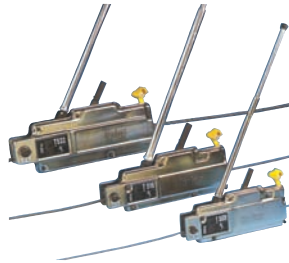

Type T
Må ikke anvendes til personløft

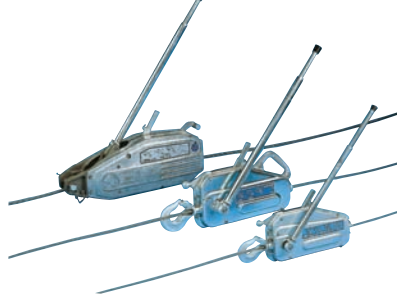

Type TU

Art. No.	Model	Lifting cap. kg	Pulling cap. kg	Weight kg		Dimensions mm		Special TIRFOR w. r.			Wire rope art. no.
				machine	w.r. 20m	machine	handle ext./closed	dia. mm	break strain kg		
05-1061108	TU-8*	800	1.200	9,4	7	528x284x113	730 - 450	8,3	4.800		05-1061208
05-1061116	TU-16*	1.600	2.500	20,4	12,5	660x360x145	1.147 - 648	11,5	9.600		05-1061216
05-1061132	TU-32*	3.200	5.000	29,4	26	685x365x156	1.147 - 648	16,3	19.200		05-1061232
05-1061008	T-508**	800	1.200	7,6	7	420x250x99	690 - 405	8,3	4.800		05-1061208
05-1061016	T-516**	1.600	2.500	15,8	12,5	530x315x127	1.147 - 648	11,5	9.600		05-1061216
05-1061032	T-532**	3.200	5.000	26,3	26	631x357x148	1.147 - 648	16,3	19.200		05-1061232

* Må anvendes til personløft, hvis den anvendes med blocstop.

** Må IKKE anvendes til personløft.

* Approved for man-riding, when used with Blocstop.

** NOT approved for man-riding.

TIRFOR lifting and pulling hoist

Tirfor lifting and pulling machines are universal and works in any position: horizontal, vertical or angled.

- Unlimited length of wire rope.
- Operates with millimetre accuracy.
- Easy and safe operation.
- Fast and easy installation.
- Simple to feed in or remove wire rope.
- Very low weight due to aluminium body.
- Easy to clean and service.
- Overload pins break at 25% overload.
- Handle bends at 50% overload.
- Increases the nominal capacity with multiple sheave blocks.
- Type TU approved for man-riding*.

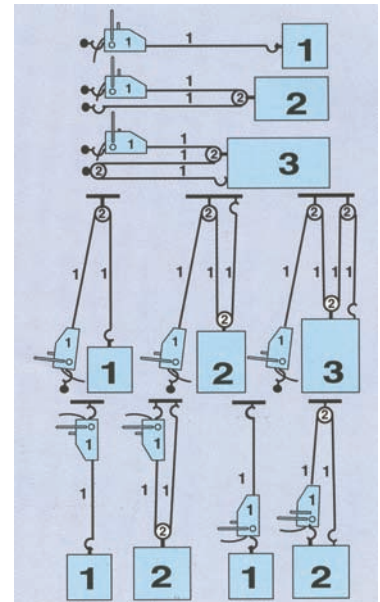

Wiretalje aluminium

POWERTEX®

POWERTEX brand aluminiums wiretalje i høj kvalitet og til konkurrencedygtig pris.

- Ubegrænset wirelængde.
- Arbejder med millimeters nøjagtighed.
- Nemt og sikker at betjene.
- Hurtig og nem installation.
- Nemt at fæde og fjerne wire.
- Meget let på grund af aluminiumshus.
- Nemt at rengøre og servicere.
- Brudstifter bryder ved 25% overlast.
- Trækstang bøjer ved 50% overlast.
- Øgning af løfte- og trækcapacitet ved brug af flerskivede blokke.

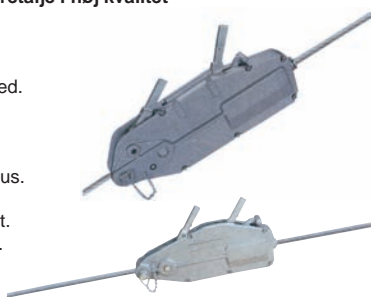

- Unlimited length of wire rope.
- Operates with millimetre accuracy.
- Easy and safe operation.
- Fast and easy installation.
- Simple to feed in or remove wire rope.
- Very low weight due to aluminium body.
- Easy to clean and service.
- Overload pins break at 25% overload.
- Handle bends at 50% overload.
- Increase the nominal capacity with multiple sheave blocks.



Art. No.	05-1063008	05-1063016	05-1063032
Art. No. Including 20 mtr. wire rope	05-1063108	05-1063116	05-1063132
Lifting capacity kg	800	1.600	3.200
Pulling capacity kg	1.200	2.400	4.000
Rated Forward Handpower N	343	441	441
Rated Forward Travel mm	> = 52	> = 55	> = 28
Rope Diameter mm	8,3	11	16
Wire Rope Safety Factor Load Capacity	5	5	5
Safety Factor & Static Load Capacity	5	5	5
Max. Overall Size mm	A	440	550
	B	265	300
	C	168	190
	D	63	77
	E	64	97
L1	-	80	80
L2	80	120	120
Weight kg	6	12	22

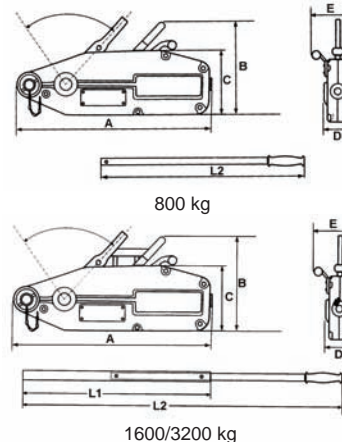

Der tages forbehold for trykfejl og udgåede varer / Specifications and products are subject to change