

## Elephant håndkædetalje

Elephant er topkvaliteten indenfor håndkædetaljer

- Dobbelt pal understøttende fejlsikker bremsemekanisme.
- Selv hvis én af palerne ved uheld bliver ubruglig, vil den anden stadig virke, og bremsesystemet forbliver sikkert.
- Palerne har også dobbelte fjedre.
- Bundkrog med kuglelejer. Kuglelejerne tillader, at den løftede byrde bliver flyttet i enhver retning, uden spænding.
- Krog udformet til lettere håndtering. Åbningen på krogen er lavet større for lettere håndtering og anhugning. Selvom krogen ved uheld skulle blive overbelastet, er der ingen fare for brud, den vil simpelthen gradvis bøje sig ud, hvilket forhindrer tab af byrde og personskaade.
- Kraftigt hus.
- Det kraftige gearhus, forstærket med fire ribber og fire slagbolte, giver nøjagtig centrering af gear og høj mekanisk effektivitet.
- Valsede hjørner på håndhjulsdæksel. Dette giver smidig håndtering af håndkæden, når den trækkes sideværts.
- Stærk og korrosionsbestandig elektrostatisk pulver maling.
- Vådfriktions bremseskiver med længere levetid.
- Unik kædestyring.
- Lasthjul med kuglelejer.
- Ankerplade forhindrer over-løft / sænkning.
- Galvaniseret H-mærket lastkæde.

## Elephant chain block

Elephant is the topquality within manual chain hoists

- Double pawls supporting fail-safe brake mechanism.
- Even if by any chance one of the two pawls becomes unserviceable, the other will still remain operative, and the brake system remains secure.
- Also, the pawl has the double springs.
- Bottom hook with thrust bearing. The thrust bearing enables the lifted load to be moved in any direction without subjecting it to stress.
- Hooks of easier handling shape. The opening of the hooks has been made wider for easier handling and working. However if by any chance the hook is overloaded there is no fear of it breaking, it will simply gradually start straightening out, avoiding any load drop or personal injury.
- Tough framing.
- The tough gear case, reinforced with four ribs and four knock pins, provides accurate gear centering and high mechanical efficiency.
- Rolled-edge hand wheel cover. This provides smooth operation of the hand chain when pulled sideways.
- Strong and least-corrosive electrostatic powder painting.
- Wet friction discs with longer life.
- Unique chain guide.
- Load sheave with roller bearing.
- Anchor plate avoiding over-lifting / lowering.
- Galvanised H-market load chain.

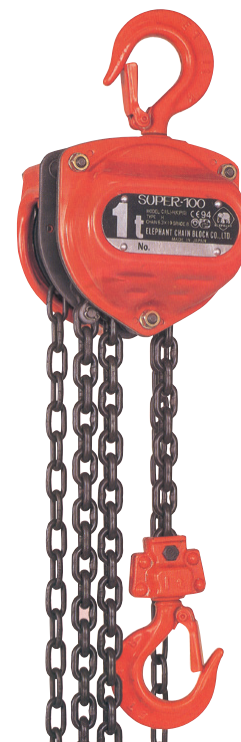
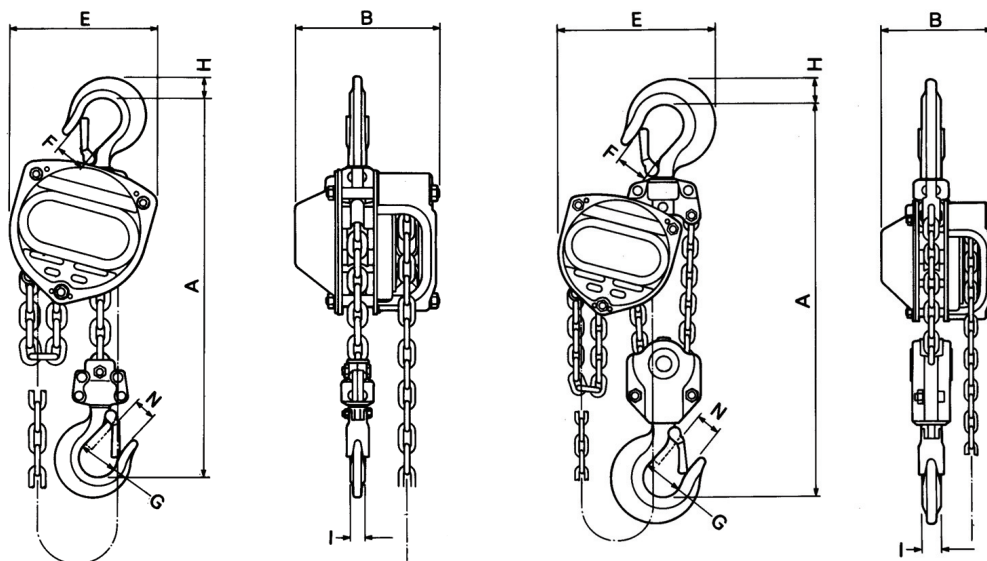

Art. No.	Model	WLL (t)	Std. lift (m)	Min. dist. between hooks (A)	Hand effort to lift full WLL (kg)	Load chain dia. x no. of pitch mm falls	Dimensions (mm)							Net weight kg
							B	E	G	H	I	N		
05-1011003	H-0,5	0,5	3	277	22	5x15	1	155	140	36	17	13	26	9,00
05-1011103	H-1	1	3	303	22,5	6,3x19	1	160	160	43	22	16	30	11,4
05-1011203	H-1,6	1,6	3	338	34	7,2x21	1	167,5	183	48	27	20	35	14,7
05-1011303	H-2	2	3	379	34	8x24	1	183	215	53	29	22	38	21,0
05-1012003	H-2,5	2,5	3	416	35	9x27	1	190	233	55	34,5	24	40	25,4
05-1011403	H-3,1	3,1	3	516	36	7,2x21	2	167,5	230	60	37	27	44	24,0
05-1011503	H-5	5	3	613	36	9x27	2	190	282	70	46	34	53	39,5
05-1012103	H-7,5	7,5	3	716	37,5	9x27	3	190	370	85	74	50	70	70,0
05-1011603	H-10	10	3	789	40,5	9x27	4	190	385	85	74	50	70	82,0

De sidste to cifre angiver antal mtr. løft.

The last two digits indicate lifting height in meters.

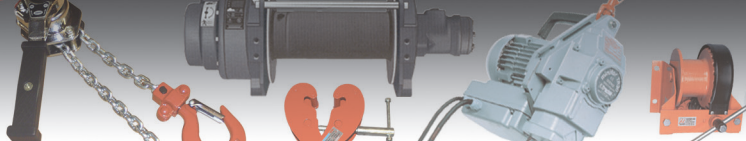

## Håndkædetalje

## Chain block

**POWERTEX**

**Powertex brand håndkædetalje i høj kvalitet og til konkurrencedygtig pris. Leveres standard med dansk manual (samt på 9 andre sprog), overensstemmelseserklæring og certifikat.**

Dobbelt palsystem.  
Lastkædehjul i alloystål.  
Individuelt produktions-nummereret.  
Galvaniseret håndkæde.  
Galvaniseret H-mærket Pewag lastkæde.  
Let og kompakt.  
Kan leveres med overlastsikring.  
Kan leveres med Powertex skub- eller håndkædeløbekat eller Powertex bjælkelemme.  
Billige reservedele.

**Powertex brand chain block in a high quality to competitive price. Standard delivered with danish manual (and 9 other languages), CE-Conformaty and certificate.**

Double pawl springmechanism.  
Hoisting sprocket in alloysteel.  
Individual manufacturing-number.  
Galvanised hand chain.  
Galvanised H-marked Pewag load chain.  
Light and compact.  
Can be delivered with overload device.  
Can be delivered with Powertex push- or geared trolley, or Powertex beam clamp.  
Cheap spare parts.



Taljer og spill

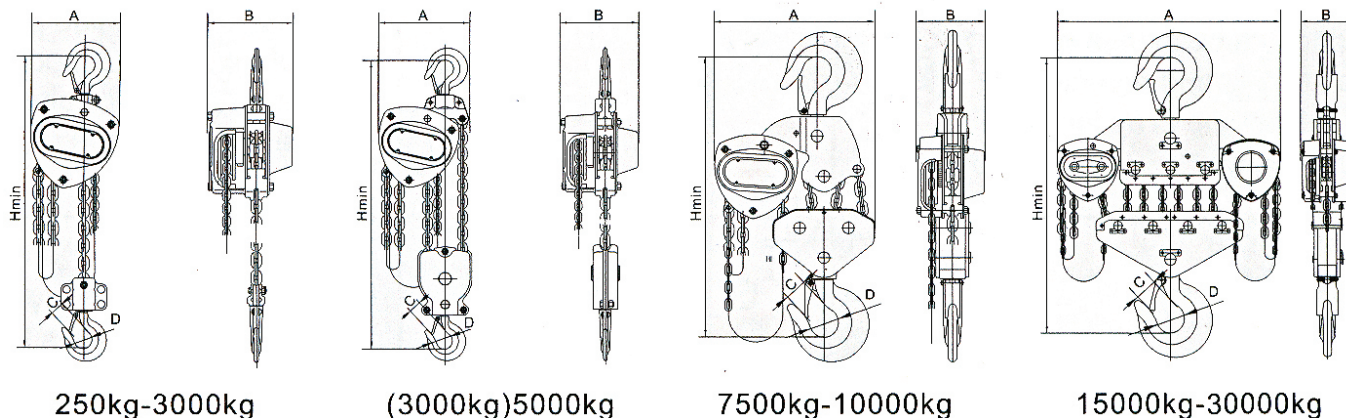

### Håndkædetalje / Chain block 0,5t / 1t / 1,5t / 2t / 3t / 5t

Art. No.	05-1014003	05-1014103	05-1014203	05-1014303	05-1014403	05-1014503	
Capacity kg	500	1.000	1.500	2.000	3.000	5.000	
Standard lift m	3	3	3	3	3	3	
Strands of load chain	1	1	1	1	2	2	
Load chain diameter mm	5x15	6x18	7x21	8x24	7x21	9x27	
Dimensions mm	A	148	172	196	210	250	
	B	132	151	173	175	189	
	C	23	26	33	35	39	45
	D (Hook inside)	35	40	45	50	55	65
	H	345	376	442	470	565	688
Net weight kg	11	12,5	17,8	19,5	29	41,3	

### Håndkædetalje / Chain block 7,5t / 10t / 15t / 20t / 30t

Art. No.	05-1016107	05-1014603	05-1016115	05-1014703	05-1016130	05-1016150	
Capacity kg	7.500	10.000	15.000	20.000	30.000	50.000	
Standard lift m	3	3	3	3	3	3	
Strands of load chain	3	4	6	8	12	20	
Load chain diameter mm	9x27	9x27	9x27	9x27	10x30	10x30	
Dimensions mm	A	430	460	718	850	705	746
	B	189	189	200	200	510	660
	C	54	54	82	80	80	120
	D (Hook inside)	75	75	106	106	110	160
	H	690	765	900	950	1.400	2.500
Net weight kg	61,5	78,5	135	190	350	850	

De sidste to cifre angiver antal mtr. løft

The last two digits indicate lifting height in meters.

Der tages forbehold for trykfejl og udgåede varer / Specifications and products are subject to change