

CERTEX elkædetalje

I SK programmet har vi pakket højtydende motorer i et kompakt design. Den ekstremt robuste konstruktion garanterer lang levetid, pålidelig drift og lave vedligeholdelses- og serviceomkostninger. Lydniveauet er reduceret til et minimum.

Standardudstyr

- Stationær talje med krogophæng.
- 2 hejsehastigheder, mulighed for frekvensstyring.
- Mekanisk overlastsikring.
- Topkrog.
- IP55 beskyttelse.
- Isolationsklasse F for motor.
- 48 volt knapstyring.
- IP65 beskyttelse på styrehåndtag, med plug adapter og nødstop.
- Køremotor med frekvensstyring, 2 hastigheder eller variabel.
- Arbejdtemperatur -20° til +40° C.
- Løbekat forsynet med anti drop og lav byggehøjde.
- Hejsemotor med termistor beskyttelse (SKD/E/F standard).

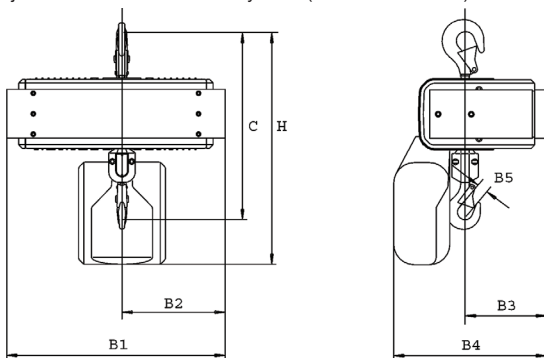

CERTEX electro chain hoist



In the SK series we have packed high performance motors into a compact design. The extremely sturdy construction guarantees long service life, reliable operation and low maintenance. Noise levels are reduced to a minimum.

Standard equipment

- Stationary hoist with hook suspension.
- 2 lifting speeds (4/1), optionally with frequency inverter.
- Mechanical overload protection.
- Top hook.
- IP55 protection.
- Motor insulation class F.
- 48 V contactor control.
- IP65 control pendant with plug adapter and EMERGENCY-STOP.
- Drive operation with frequency inverter, 2-speed or variable.
- Suitable for ambient temperatures of between -20° and +40° C.
- Single-girder trolley equipped with drop stops.
- Lifting motor with thermal protection (SKD/E/F standard).
- Upper and lower hoisting limit switch.



Art. No.	Type	Load kg	FEM	Hoisting speed m/min	No. of falls	Chain size	B1	B2	B3 mm	B4*	B5	C	H*	Hoist motor kW	Net weight kg
05-2011001	SKa 080.12	125	1Bm	8,0/2,0	1	3,1 x 9,3	308	136	147	250	18	310	312	0,20/0,05	14
05-2011010	SKa 082.22	125	2m	4,0/1,0	2	3,1 x 9,3	308	136	132	250	18	334	312	0,20/0,05	14
05-2011002	SKa 080.22	250	1Bm	4,0/1,0	2	3,1 x 9,3	308	136	132	250	18	334	312	0,20/0,05	15
05-2011011	SKb 082.12	250	2m	8,0/2,0	1	4,8 x 12,5	422	199	160	300	18	366	455	0,80/0,20	27
05-2011003	SKb 080.12	500	1Bm	8,0/2,0	1	4,8 x 12,5	422	199	160	300	18	366	455	0,80/0,20	27
05-2011012	SKC 082.12	500	2m	8,0/2,0	1	6,8 x 17,8	504	260	200	405	22	448	575	1,70/0,40	55
05-2011004	SKb 080.22	1.000	1Bm	4,0/1,0	2	4,8 x 12,5	422	199	139	300	22	416	455	0,80/0,20	30
05-2011013	SKC 080.12	1.000	1Bm	8,0/2,0	1	6,8 x 17,8	504	260	200	405	22	448	575	1,70/0,40	55
05-2011014	SKC 082.22	1.000	2m	4,0/1,0	2	6,8 x 17,8	504	260	171	405	35	509	575	1,70/0,40	60
05-2011005	SKC 080.22	2.000	1Bm	4,0/1,0	2	6,8 x 17,8	504	260	171	405	35	509	575	1,70/0,40	60
05-2011015	SKD 080.22	2.000	2m	4,0/1,0	2	9,0 x 27,0	518	313	196	469	43	658	774	3,50/0,90	110
05-2011016	SKD 081.22	3.200	1Am	4,0/1,0	2	9,0 x 27,0	518	313	196	469	43	658	774	3,50/0,90	110
05-2011017	SKF 062.22	3.200	2m	3,2/0,75	2	11,3 x 31,0	518	313	196	469	43	658	774	3,50/0,90	125
05-2011018	SKE 081.22	4.000	1Am	4,0/1,0	2	11,3 x 31,0	518	313	196	469	43	658	774	3,50/0,90	125
05-2011019	SKF 061.22	5.000	1Am	3,2/0,75	2	11,3 x 31,0	518	313	196	469	43	658	774	3,50/0,90	125

* For 6 mtr. kæde

*For 6 mtr. chain

Ekstraudstyr

- Skubløbekat.
- Elløbekat med 2 hastigheder, eller variabel hastighed.
- Ekstrem lav byggehøjde.
- Med frekvens omformer for trinløs hastighed.
- Lastkæde og krog i rustfri.
- Beskyttende regnafskærmning.
- Timer i servicemeter.
- RadioMaster styring.
- Termistor beskyttelse på hejsemotor og køremotor
- Leddelt boogie-løbekat for kørsel på kurver.
- Eksplosionssikker version.
- HandyMaster styring for højere vindmøller.
- Med ekstreme løftehøjder for brug i vindmøller.
- Version for fødevarerindustrien.
- Eksplosionssikker model

Extras

- Push travel trolley.
- Motor drive system with 2-speed or variable speed control.
- Extremely low headroom trolley.
- With frequency inverter for stepless hoisting and lowering.
- Load chain and hook in stainless steel.
- Protective rain covers.
- Hours in service meter.
- RadioMaster radio control system.
- Thermal protection for lifting motor and trolley drive.
- Articulated boogie trolley for curved runway.
- Push or motor travel trolley for ProfileMaster system.
- Explosion proof version.
- HandyMaster control pendant for increased efficiency
- With extreme lifting heights for windmill applications
- Version for the food industry.
- Explosion proof version.

Der tages forbehold for trykfejl og udgåede varer / Specifications and products are subject to change